

# 30" RESIDENTIAL RANGE

## STANDARD FEATURES

### RANGE TOP

- (2) 17,000 BTU, (1) 13,000 BTU and (1) 9,000 BTU sealed burners
- Sealed burners simmer at 140°F, all with infinite setting controls
- Sealed, one-piece, stainless steel burner top surface
- Child safe push-and-turn top burner controls
- All top burners have flame-sensing reignition, in the event the flame goes out
- Blue LED indicator lights for each burner
- Continuous and flush commercial-grade grates allow for easy transferring of pots and pans across the entire cooking surface

### OVEN FUNCTIONS

- Convection bake, dehydrate and defrost
- Standard bake and broil
- Industry's largest oven cavity at 4.8 cu. ft. which accommodates commercial grade baking sheets
- 30,000 BTU hidden bake oven burner
- 15,500 BTU **Inconel**® banquet broiler burner produces 1,500°F broiling temperatures
- Commercial-grade stainless steel construction and insulation
- Commercial-grade high temperature porcelain oven interior
- 2 oven lights
- 2 oven racks with 6 rack positions

### ACCESSORIES

- 4" Riser
- 20" Riser with shelf
- 20" Riser
- Leg cap (Set of two)
- Wok ring
- Removable griddle plate
- Island back
- Curb base
- Cutting board

### ELECTRICAL REQUIREMENTS

- 120 VAC, 10 Amps, Single Phase

### OPERATING GAS PRESSURE

- NAT: 5.0 inches WC
- LP: 10.0 inches WC

### WARRANTY

One year limited warranty, parts and labor

## INNOVECTION® CONVECTION OVEN TECHNOLOGY

### Innovection® Convection Oven Technology

Even, turbulent heat distribution is essential when baking, roasting, and dehydrating food. The American Range **Innovection**® convection oven technology utilizes dual convection motors and louvered side panels to enhance uniform heat distribution throughout the large oven cavity. The strategic placement of the dual **Innovection**® convection motors blended with the louvered side panel design ensures consistent heat distribution; even when challenged with cooking the largest turkey, ham or roast.



### ■ Innovection® Convection Oven is Green Technology

The highly efficient design of the Innovection® Convection Oven utilizes 19% less gas versus a standard sealed convection oven.

## D E S I G N E R C O L O R S

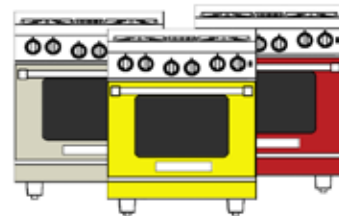
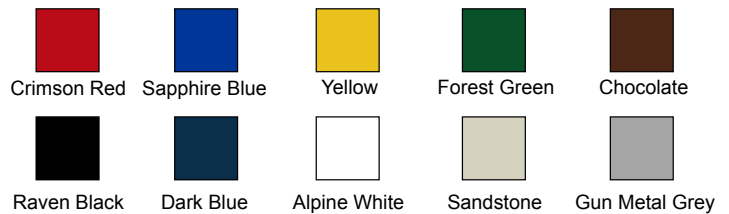

Custom colors are available with "RAL" number

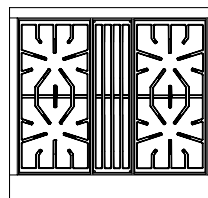
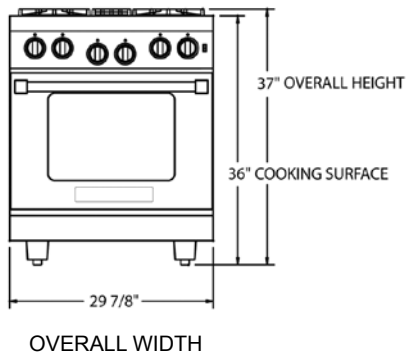

ARR-304

