

AMERICAN RANGE

PROFESSIONAL QUALITY COOKING EQUIPMENT

TITAN SERIES

36" Range with Sealed Gas Step-up Burners



ARR-366IS

(shown with optional leg caps)

DESIGN



CLASS



FUNCTION

DESIGNED & BUILT IN USA
PROFESSIONAL COOKING EQUIPMENT

36" RESIDENTIAL GAS RANGE

RANGE TOP FEATURES

- Sealed burners deliver exceptional performance at every level setting and lift off to provide easy cleanup
- 3 sizes of burners to serve your everyday needs: 17,000 BTU (lg), 13,000 BTU (med), 9,000 BTU (sm)
- Variable infinite flame settings for all sealed top burners
- Fail-safe system ensures re-ignition in the event the flame goes out even on the lowest burner setting
- Step-up range provides 2 unequal levels of cooking surface
- Elevated rear burners provide easy access to saute pans and allow larger pots to be used consecutively
- Sealed Single Piece tool-ported porcelainized cook top can hold more than a gallon of spills
- Analog controls provide easy, push and turn operation ensuring child safety
- Blue LED light indicate flame and oven
- Heavy metal die-cast black satin knobs with chrome bezels
- Stainless Steel Island Back Trim is included and installed

OVEN FEATURES

- Multiple functions include: Standard Bake, Innovention® Convection Bake, Infrared Broil and Fan mode
- Innovention® System with convection fan optimizes uniform air flow
- Two chrome racks glide at 6 cooking levels on heavy chrome side supports
- Accommodates full size commercial sheet pan
- Two lights in each oven are controlled from front panel switch

INNOVECTION® CONVECTION OVEN TECHNOLOGY

Balanced turbulent heat distribution is essential when baking, roasting, and dehydrating food. The American Range Innovention® convection oven technology features dual convection motors and louvered side panels to enhance uniform heat distribution throughout the large oven cavity. The strategic placement of the dual Innovention® convection fans ensures consistent heat distribution even when challenged with cooking the largest turkey, ham or roast.



INNOVECTION® CONVECTION OVEN IS GREEN TECHNOLOGY

The highly efficient design of the Innovention® Convection Oven uses 19% less gas versus a standard convection oven.

TECHNICAL SPECIFICATIONS

Overall Oven Capacity	6.0 CU. FT.
Oven Dimensions	20 - 1/2" W x 20 - 1/2" D x 15 - 1/2" H
Surface Burner Rating	17,000 BTU (lg) - 13,000 BTU (md) - 9,000 BTU (sm)
Infrared Broiler	18,000 BTU
Oven Bake Burner	30,000 BTU
Total Gas Connection Rating	ARR-366IS 134,000 BTU
Gas Supply	7" W.C. Natural, 11" W.C. Propane
Electrical Supply	120 VAC 15 AMP 60 Hz Single Phase
Shipping Weight	460 Lbs

COLOR KNOBS

red knobs fits: ARR-366IS	KSR-GF36
burgundy knobs fits: ARR-366IS	KSB-GF36

ACCESSORIES & OPTIONS

S/S Curb base	ARR-36CB-T	Casters (Set of 2)	ARR-2CAS-T	Wok Adapter	ARR-WOK
S/S Leg Caps (2)	ARR-2LC-T	Porcelainized Broiler Pan	R31005		

CUSTOMIZE YOUR RANGE: Now you can customize your American Range to match your kitchen setting. Pick from numerous colors and finishes to give your range a unique one-of-a-kind look. For more details regarding color and finish options, go to our website: www.americanrange.com.

DESIGNER COLORS



DESIGNER FINISHES



N = Natural gas Must ship from factory with proper gas type
L = LP Gas Must provide **N** or **L** after model number for type of gas needed.
Example: ARR-304-DF-L represents unit to be built for LP gas.
Note: Must specify elevation if over 1000 ft when ordering.

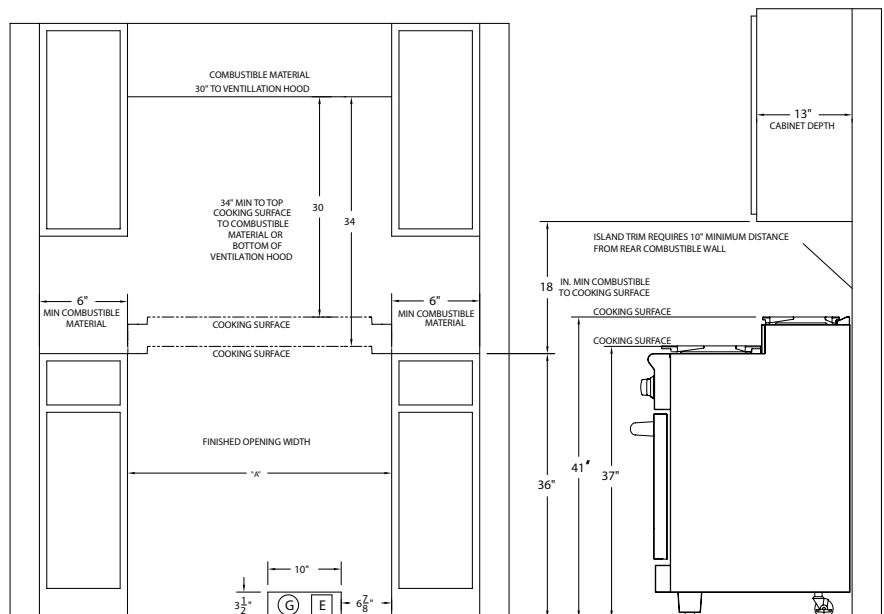
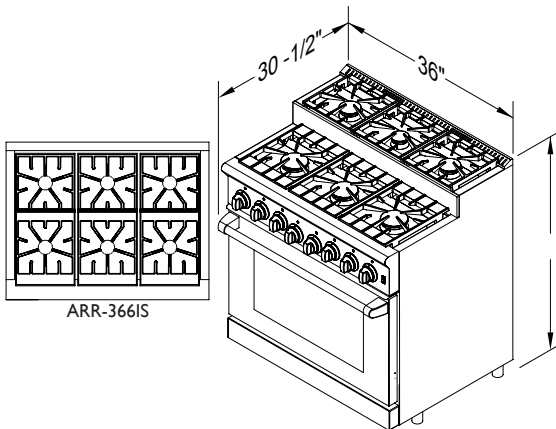

ISLAND OR PENINSULA INSTALLATIONS: 10" MINIMUM CLEARANCE FROM BACK OF RANGE TO COMBUSTIBLE SURFACE ISLAND TRIM IS 0 IN. CLEARANCE TO NON-COMBUSTIBLE SURFACE. NO SIDE WALL ABOVE COOKING SURFACE. (G) (E) LOCATION OF GAS AND ELECTRICAL SUPPLY