

# AMERICAN RANGE

PROFESSIONAL QUALITY COOKING EQUIPMENT

## TITAN SERIES

36" Dual-Fuel Range with Sealed Gas Step-up Burners  
and Electric Self-Clean Oven



ARR-366ISDF

(shown with optional leg caps)

DESIGN



CLASS



FUNCTION

DESIGNED & BUILT IN USA  
PROFESSIONAL COOKING EQUIPMENT

# 36" RESIDENTIAL DUAL FUEL RANGE

## RANGE TOP FEATURES

- Step-up range provides 2 unequal levels of cooking surface
- Elevated rear burners provide easy access to sauté pans, & allow larger pots to be used consecutively
- 3 sizes of burners to serve your everyday needs: 17,000 BTU (lg), 13,000 BTU (med), 9,000 BTU (sm)
- Sealed burners deliver exceptional performance at every level setting and lift off to provide easy cleanup
- Fail-safe system ensures re-ignition in the event the flame goes out even on the lowest burner setting
- Sealed Single Piece tooled stainless steel cook tops can hold more than a gallon of spills
- Blue LED lights indicate flame and oven functions provided with every knob
- Heavy metal die-cast black satin knobs with chrome bezels
- Analog controls provide easy, push and turn operation ensuring child safety
- Electronic keypad with blue VFD display

## OVEN FEATURES

- Commercial grade high performance thermal insulation keeps kitchen cool
- Programmable timed self clean for effortless oven maintenance
- Accommodates full size commercial sheet pan
- Two chrome racks glide at 6 cooking levels on heavy chrome side supports
- Commercial grade porcelainized oven interior for simple cleaning
- 3,500 Watt Instagrill™ broiler reaches searing temperature in 3 seconds
- Infrared energy from hidden bake and broil elements shine through high transparency glass ceramic windows
- Stainless steel air flow directors provide even distribution of convection air for uniform oven temperatures
- Traditional and Convection Bake can be controlled from 150°F to 550°F

## ACCESSORIES & OPTIONS

Stainless Steel Curb base	ARR-30CB-T	Casters (Set of 2)	ARR-2CAS-T	Wok Adapter	ARR-WOK-T
Stainless Steel Leg Caps (2)	ARR-2LC-T	Porcelainized Broiler Pan	R31005		

**CUSTOMIZE YOUR RANGE:** Now you can customize your American Range to match your kitchen setting. Pick from numerous colors and finishes to give your range a unique one-of-a-kind look. For more details regarding color and finish options, go to our website: [www.americanrange.com](http://www.americanrange.com).

### DESIGNER COLORS



### DESIGNER FINISHES



**N** = Natural gas    Must ship from factory with proper gas type  
**L** = LP Gas        Must provide **N** or **L** after model number for type of gas needed.  
**Example: ARR-304-DF-L** represents unit to be built for **LP** gas.  
**Note:** Must specify elevation if over 1000 ft when ordering.

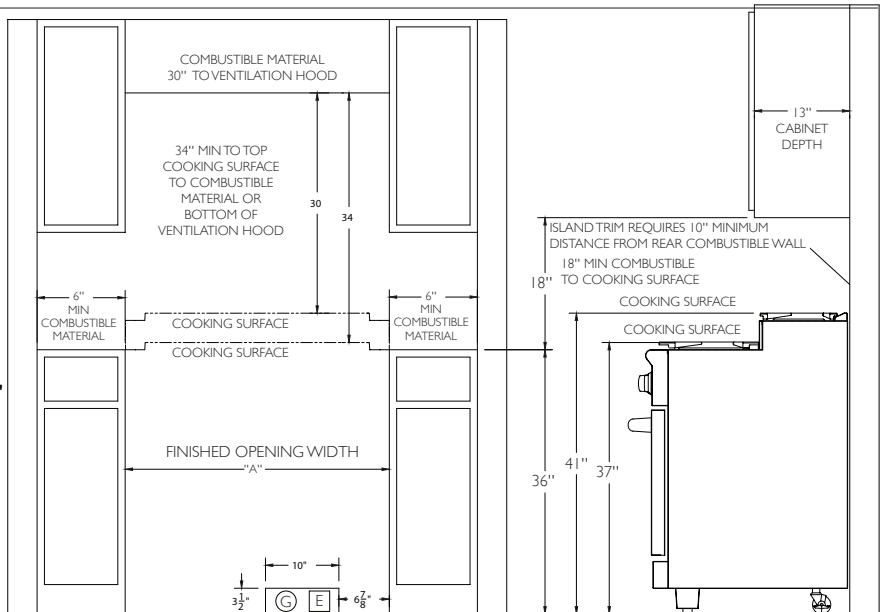
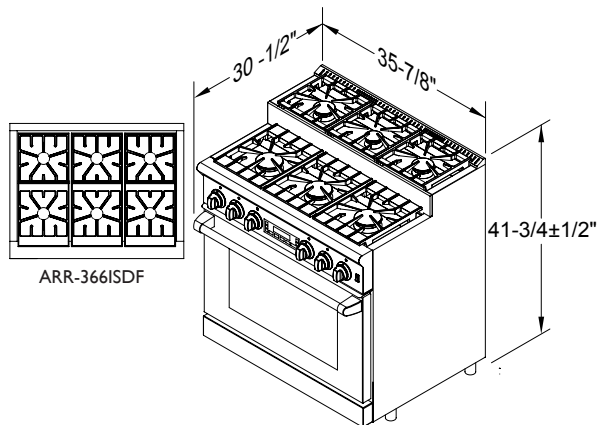

ISLAND OR PENINSULA INSTALLATIONS 10" MINIMUM CLEARANCE FROM BACK OF RANGE TO COMBUSTIBLE SURFACE ISLAND TRIM IS 0".  
 CLEARANCE TO NON COMBUSTIBLE SURFACE  
 NO SIDE WALL ABOVE COOKING SURFACE  
 (G) (E) LOCATION OF GAS AND ELECTRICAL SUPPLY

## STRAIGHT CONVECTION™ TECHNOLOGY

American Range is pleased to introduce Straight Convection™ Technology. Borrowing from the aerospace industry, we've circled our convection bake fan with a powerful ring heater - and straightened out the hot air stream using proprietary air directors. The result is shorter cooking times and more uniform heat transfer for multiple rack cooking - saving time and energy!

## COMMERCIAL HERITAGE

American Range introduces the new dual fuel range for the home - a kitchen cooking product for the best of both worlds. The dual fuel range combines the accurate temperature control of the electric oven cell - with the speed and power of our industry-leading gas range top. When you add in our rugged, commercial design and construction heritage, as can be expected, the whole is far greater than the sum of its parts.

## TECHNICAL SPECIFICATIONS

Overall Oven Capacity	5.7 CU. FT.
Oven Dimensions	31 - 1/2" W x 20 - 3/4" D x 15" H
Surface Burner Rating	17,000 BTU (lg) - 13,000 BTU (md) - 9,000 BTU (sm)
Infrared Broiler Element	3,500 Watts - (30" oven)
Oven Bake Burner Element	3,500 Watts - (30" oven)
Convection Ring Element	2,200 Watts - (30" oven)
Total Gas Connection Rating per model #	ARR-366ISDF 86,000 BTU
Gas Supply	7" W.C. Natural, 11" W.C. Propane
Electrical Supply	240 VAC 30 AMP 60 Hz Single Phase
Shipping Weight	460 Lbs

## COLOR KNOBS

red knobs fits: ARR-366ISDF	KSR-DF36
burgundy knobs fits: ARR-366ISDF	KSB-DF36