



PROFESSIONAL QUALITY COOKING EQUIPMENT

HERITAGE CLASSIC SERIES

60" Range with Sealed Gas Burners



ARR-606GDGR

(shown with optional 4" stub back and leg caps)

DESIGN



CLASS



FUNCTION

DESIGNED & BUILT IN USA
PROFESSIONAL COOKING EQUIPMENT

60" RESIDENTIAL GAS RANGE

RANGE TOP FEATURES

- Sealed burners deliver exceptional performance at every level setting and lift off to provide easy cleanup
- 3 sizes of burners to serve your everyday needs: 17,000 BTU (lg), 13,000 BTU (med), 9,000 BTU (sm)
- Variable infinite flame settings for all sealed top burners
- Fail-safe system ensures re-ignition in the event the flame goes out even on the lowest burner setting
- Continuous and flush commercial-grade cast iron grates allow for easy transfer of pots and pans across the entire cooking surface
- Sealed Single Piece tooled stainless steel cook top can hold more than a gallon of spills
- Analog controls provide easy, push and turn operation ensuring child safety
- Blue LED light indicate flame and oven functions provided with every knob
- Heavy metal die-cast black satin knobs with chrome bezels
- Stainless Steel Island Back Trim is included and installed

OVEN FEATURES

- Multiple functions include: Standard Bake, Innovention® Convection Bake, Infrared Broil and Fan mode
- Innovention® System with convection fan optimizes uniform air flow
- Two chrome racks glide at 6 (including base) cooking levels on heavy chrome side supports
- Accommodates full size commercial sheet pan
- Two lights in each oven are controlled from the front panel switch

INNOVECTION® CONVECTION OVEN TECHNOLOGY

Balanced turbulent heat distribution is essential when baking, roasting, and dehydrating food. The American Range Innovention® convection oven technology features dual convection motors and louvered side panels to enhance uniform heat distribution throughout the large oven cavity. The strategic placement of the dual Innovention® convection fans ensures consistent heat distribution even when challenged with cooking the largest turkey, ham or roast.



INNOVECTION® CONVECTION OVEN IS GREEN TECHNOLOGY

The highly efficient design of the Innovention® Convection Oven uses 19% less gas versus a standard convection oven.

TECHNICAL SPECIFICATIONS

Overall Oven Capacity	4.9 CU. FT. each oven		
Oven Dimensions	26-1/2"W x 20-1/2" D x 15-1/2" H each oven		
Surface Burner Rating	17,000 BTU (lg) - 13,000 BTU (md) - 9,000 BTU (sm)		
Griddle Burner Rating	20,000 BTU for every 11" section		
Grill Burner Rating	18,000 BTU for every 11" section		
Infrared Broiler	18,000 BTU each oven		
Oven Bake Burner	30,000 BTU each oven		
Total Gas Connection Rating per model #	ARR-6062GD	222,000 BTU	6 burners & double griddle
	ARR-606GDGR	220,000 BTU	6 burners, griddle & grill
	ARR-606X2GR	218,000 BTU	6 burners & double grill
Gas Supply	7" W.C. Natural, 11" W.C. Propane		
Electrical Supply	120VAC 15 AMP 60 Hz Single Phase		
Shipping Weight	780 Lbs		

ACCESSORIES AND OPTIONS

Island back (standard) ARR-60SIB-H	Casters (Set of 3) ARR-3CAS-H	24" Griddle Cover ARR-GDCOV24-S-H	22" Chrome Grooved Griddle MCGG-H
Island back (welded) ARR-60IB-H	12" Cutting Board ARR-CUTB12-H	24" Grill Cover ARR-GRCOV24-H	22" Chrome Griddle w/ Separator MCSP-H
4" Stub Back ARR-604SB-H	12" Griddle Cover ARR-GDSCOV12-S-H	11" Chrome Flat Griddle Plate MC11-FS-H	Porcelainized Broiler Pan R31005
20" High back w/ Shelf ARR-6021HBS-H	12" Grill Cover ARR-GRCOV12-S-H	11" Chrome Grooved Griddle Plate MC11-GG-H	Wok Adapter ARR-WOK
S/S Curb base ARR-60CB-H	12" Griddle Plate ARR-PGP12-H	22" Chrome Flat Griddle Plate MC22-FS-H	
Stainless Steel Leg Caps (3) ARR-3LC-H	24" Griddle Plate ARR-PGP24-H	22" Chrome L- Flat R - Grooved Griddle MC-HG-H	

CUSTOMIZE YOUR RANGE: Now you can customize your American Range to match your kitchen setting. Pick from numerous colors and finishes to give your range a unique one-of-a-kind look. For more details regarding color and finish options, go to our website: www.americanrange.com.



DESIGNER COLORS



DESIGNER FINISHES



N = Natural gas
L = LP Gas
Must ship from factory with proper gas type.
Must provide **N** or **L** after model number for type of gas needed.
Example: ARR-304
Must specify elevation if over 1000 ft. when ordering.

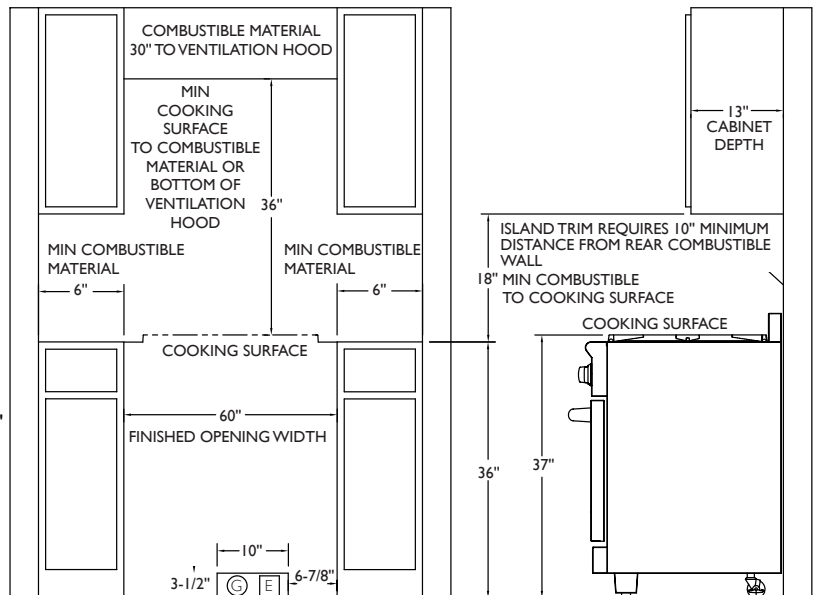
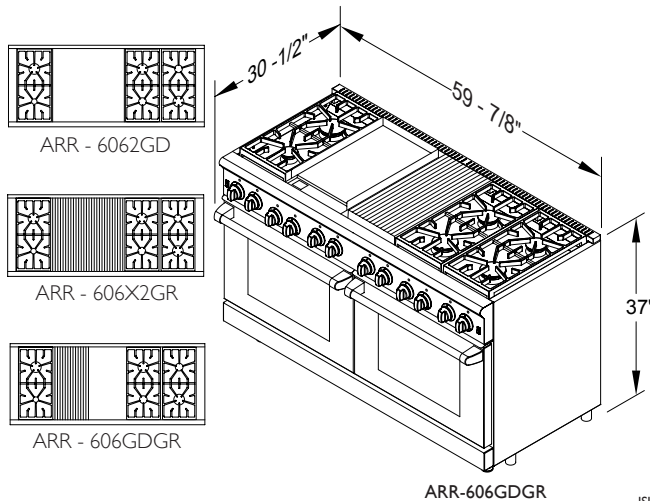

ISLAND OR PENINSULA INSTALLATIONS 10" MINIMUM CLEARANCE FROM BACK OF RANGE TO COMBUSTIBLE SURFACE ISLAND TRIM IS 0".
CLEARANCE TO NON COMBUSTIBLE SURFACE
NO SIDEWALL ABOVE COOKING SURFACE
ⓐ ⓑ LOCATION OF GAS AND ELECTRICAL SUPPLY